

# Wall bracket

CDT

Part instruction

Rev. 2.1

da • se • en • de • fr • ru • sk • it

**Dantherm**<sup>®</sup>  
CONTROL YOUR CLIMATE

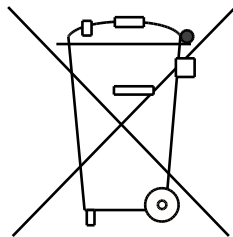

Der tages forbehold for trykfejl og ændringer  
Dantherm can accept no responsibility for possible errors and changes  
Irrtümer und Änderungen vorbehalten  
Dantherm n'assume aucune responsabilité pour erreurs et modifications éventuelles

**DA** Vægophæng, CDT

**Funktionsbeskrivelse**

Ved brug af vægophæng får man affugteren op i højde og har på den måde fri gulvplads. Kondensatvandet ledes ud i et afløb med hældning eller pumpes op med kondensatpumpe (option).

**Dele**

Sættet består af følgende dele:

- 1 stk. støttefront til løftegreb ①
- 1 stk. støttebag for fodstøtte ②
- 2 stk. vægkonsol ③
- 1 stk. vange, højre ④
- 1 stk. vange, venstre ⑤
- 10 stk. pladeskruer

**Værktøj**

Der er ikke brug for specialværktøj for at montere vægophænget.

**Advarsel**

Benyt passende skruer og dyvler (ikke medleveret) alt efter væggen beskaffenhed. Afstande på indsuignings- og afkastsiden skal overholdes iht. anvisningerne i affugterens manual.

Affugteren skal være slukket før den placeres på vægophænget.

**Montage**

Følg denne vejledning for at montere vægophænget og placere affugteren på ophænget:

Trin	Handling														
1	Saml vægkonsollen ③ og vangerne ④/⑤ med pladeskruer, brug evt. tegningen i trin 2/3														
2	<p>Monter vægophænget på væggen ved at starte med at markere op på væggen, hvor der skal bores:</p> <table border="1" style="margin-left: auto; margin-right: auto;"> <thead> <tr> <th></th> <th>CDT 20/30/30S</th> <th>CDT 40/40S/60</th> </tr> </thead> <tbody> <tr> <td>A</td> <td>335 mm</td> <td>360 mm</td> </tr> <tr> <td>B</td> <td>175 mm</td> <td>175 mm</td> </tr> </tbody> </table>		CDT 20/30/30S	CDT 40/40S/60	A	335 mm	360 mm	B	175 mm	175 mm					
	CDT 20/30/30S	CDT 40/40S/60													
A	335 mm	360 mm													
B	175 mm	175 mm													
3	<p>Skrue ophænget fast på væggen med passende skruer for væggen (ikke medleveret)</p> <table border="1" style="margin-left: auto; margin-right: auto;"> <thead> <tr> <th>CDT</th> <th>20</th> <th>30</th> <th>40</th> <th>60</th> <th>30S</th> <th>40S</th> </tr> </thead> <tbody> <tr> <td>Kg</td> <td>28</td> <td>32</td> <td>42</td> <td>46</td> <td>34</td> <td>45</td> </tr> </tbody> </table>	CDT	20	30	40	60	30S	40S	Kg	28	32	42	46	34	45
CDT	20	30	40	60	30S	40S									
Kg	28	32	42	46	34	45									
4	Placer affugteren på vangerne ④/⑤, og fikser den med støttefronten ① og støttebag ②. Støtterne ①/② kan placeres, så udblæsningssiden enten vender til højre eller venstre. På tegningen er udblæsningssiden til venstre														

**SV** Väggs montage, CDT

**Funktions-  
beskrivning**

Vid väggmontage får man avfuktaren upp ifrån golv och fri gör yta. Kondensatvandet släpps ut i avlopp med lutning eller pumpas upp med kondensatpump (option).

**Delar**

Följande delar ingår:

- 1 stk. främre stödskena till lyfthantag ①
- 1 stk. bakre stödskena för fotstöd ②
- 2 stk. väggkonsoller ③
- 1 stk. montage arm, höger ④
- 1 stk. montage arm, vänster ⑤
- 10 stk. Plåtskruv

**Verktyg**

Inget behov av special verktyg vid montering av väggmontage.

**Observera**

Använd passande montageskruvar och dymlingar (ej medlevererat) efter väggens beskaffenhet.

Observera avståndet på inlufts- och avluftsidan. Anvisningarna är föreskrivna i avfuktarens manual.

Avfuktaren skall vara avstängd före placering på vägg.

**Montage**

Följ instruktionerna för att montera vägg montaget och placera avfuktaren på upphängningen:

Steg	Handling																	
1	Montera väggkonsollen ③ och montage armarna ④/⑤ med plåtskruvarna, använd . teckningen i steg 2/3																	
2	Börja med att markera upp på väggen, var det skall boras. Montera därefter väggmontaget på väggen: <table border="1" style="margin: 10px auto;"> <thead> <tr> <th></th> <th>CDT 20/30/30S</th> <th>CDT 40/40S/60</th> </tr> </thead> <tbody> <tr> <td>A</td> <td>335 mm</td> <td>360 mm</td> </tr> <tr> <td>B</td> <td>175 mm</td> <td>175 mm</td> </tr> </tbody> </table>		CDT 20/30/30S	CDT 40/40S/60	A	335 mm	360 mm	B	175 mm	175 mm								
	CDT 20/30/30S	CDT 40/40S/60																
A	335 mm	360 mm																
B	175 mm	175 mm																
3	Skruva väggmontaget på väggen med passande skruvar för väggen (ej med levererat) <table border="1" style="margin: 10px auto;"> <thead> <tr> <th></th> <th>CDT</th> <th>20</th> <th>30</th> <th>40</th> <th>60</th> <th>30S</th> <th>40S</th> </tr> </thead> <tbody> <tr> <td>Kg</td> <td></td> <td>28</td> <td>32</td> <td>42</td> <td>46</td> <td>34</td> <td>45</td> </tr> </tbody> </table>		CDT	20	30	40	60	30S	40S	Kg		28	32	42	46	34	45	
	CDT	20	30	40	60	30S	40S											
Kg		28	32	42	46	34	45											
4	Placera avfuktaren på skenorna ④/⑤, och fixera den på främre ① och bakre stödskenorna ②. Skenorna ①/② kan placeras, så utblåset är antingen till höger eller vänster. På bilden är utblåssidan till vänster.																	

**EN** Wall suspension kit, CDT

**Functional description**

Using a wall bracket will give you more free floor area. Discharge condensate into a drain with slope or pump up condensate using a condensate pump (option).

**Parts**

The wall suspension kit consists of the following parts:

- 1 support for the lifting handle ①
- 1 rear support for the foot ②
- 2 wall brackets ③
- 1 bar, right hand side ④
- 1 bar, left hand side ⑤
- 10 sheet metal screws

**Tools**

No special tools are required to mount the wall suspension kit.

**Warning**

Use appropriate mounting screws and dowels (not supplied) which are suitable for the actual wall material.  
Please observe the recommended minimum spaces for air inlet and air outlet which are mentioned in the service manual. Turn off the dehumidifier before placing it on the wall brackets.

**Montage**

Follow these steps to mount the wall suspension brackets and hang the dehumidifier on the brackets:

Step	Action														
1	Assemble the wall bracket ③ and the bars ④/⑤ by means of sheet metal screws, you may use the drawing referred to in steps 2/3														
2	Mount the brackets on the wall, after having drilled holes in accordance with the table below: <table border="1" style="margin: 10px auto;"> <thead> <tr> <th></th> <th>CDT 20/30/30S</th> <th>CDT 40/40S/60</th> </tr> </thead> <tbody> <tr> <td>A</td> <td>335 mm</td> <td>360 mm</td> </tr> <tr> <td>B</td> <td>175 mm</td> <td>175 mm</td> </tr> </tbody> </table>		CDT 20/30/30S	CDT 40/40S/60	A	335 mm	360 mm	B	175 mm	175 mm					
	CDT 20/30/30S	CDT 40/40S/60													
A	335 mm	360 mm													
B	175 mm	175 mm													
3	Fix the wall suspension kit to the wall by means of appropriate screws (not included) <table border="1" style="margin: 10px auto;"> <thead> <tr> <th>CDT</th> <th>20</th> <th>30</th> <th>40</th> <th>60</th> <th>30S</th> <th>40S</th> </tr> </thead> <tbody> <tr> <td>Kg</td> <td>28</td> <td>32</td> <td>42</td> <td>46</td> <td>34</td> <td>45</td> </tr> </tbody> </table>	CDT	20	30	40	60	30S	40S	Kg	28	32	42	46	34	45
CDT	20	30	40	60	30S	40S									
Kg	28	32	42	46	34	45									
4	Place the dehumidifier on the bars ④/⑤, and fix it with the supports ① and ②. The supports ①/② can be placed in two ways: either for air outlet to the right or air outlet to the left. On the drawing air outlet turns to the left.														

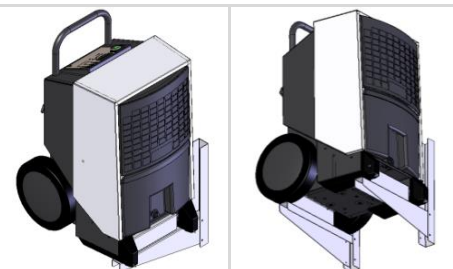
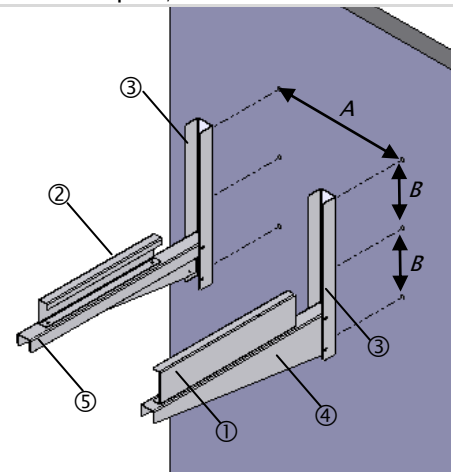

**DE** Wandkonsole zu Luftentfeuchter CDT

**Funktions-  
Beschreibung**

Mit der Wandkonsole lässt sich der Luftentfeuchter CDT an der Wand aufhängen und der Bodenplatz bleibt dadurch frei. Ablauf des Kondensatwassers mit Gefälle in einen Ablauf oder mit Kondensatpumpe hochpumpen (Option).

**Teile**

Der Satz besteht aus folgenden Teilen:

- 1 vorderes Fixierstück für Hebegriff ①
- 1 hinteres Fixierstück für die Füße ②
- 2 Wandhalterungen ③
- 1 Support, rechts ④
- 1 Support, links ⑤
- 10 Blechschrauben

**Werkzeug**

Die Montage der Wandkonsole benötigt kein Spezialwerkzeug

**Warnung**

Geeignete Schrauben und Dübel (nicht enthalten) gemäß der Beschaffenheit der Wand verwenden.

Abstand A entsprechend dem CDT-Typ gemäss den Angaben in der unten stehenden Tabelle.

Luftentfeuchter CDT erst nach Wandmontage am Strom einstecken.

**Montage**

Bitte bei der Wandmontage der Konsole und der Installation des Entfeuchters gemäss folgenden Schritten vorgehen:

Schritt	Tätigkeit															
1	Die Wandhalterungen ③ und die Supports ④/⑤ mit Blechschrauben verbinden (siehe Illustration zu Schritten 2 und 3)															
2	Folgende Masse (siehe Tabelle und Illustration) bei der Montage an der Wand einhalten: <table border="1" style="margin: 10px auto;"> <thead> <tr> <th></th> <th>CDT 20/30/30S</th> <th>CDT 40/40S/60</th> </tr> </thead> <tbody> <tr> <td>A</td> <td>335 mm</td> <td>360 mm</td> </tr> <tr> <td>B</td> <td>175 mm</td> <td>175 mm</td> </tr> </tbody> </table>		CDT 20/30/30S	CDT 40/40S/60	A	335 mm	360 mm	B	175 mm	175 mm						
	CDT 20/30/30S	CDT 40/40S/60														
A	335 mm	360 mm														
B	175 mm	175 mm														
3	Wandkonsole mit geeigneten Schrauben (nicht enthalten) befestigen: <table border="1" style="margin: 10px auto;"> <thead> <tr> <th></th> <th>CDT 20</th> <th>CDT 30</th> <th>CDT 40</th> <th>CDT 60</th> <th>CDT 30S</th> <th>CDT 40S</th> </tr> </thead> <tbody> <tr> <td>Kg</td> <td>28</td> <td>32</td> <td>42</td> <td>46</td> <td>34</td> <td>45</td> </tr> </tbody> </table>		CDT 20	CDT 30	CDT 40	CDT 60	CDT 30S	CDT 40S	Kg	28	32	42	46	34	45	
	CDT 20	CDT 30	CDT 40	CDT 60	CDT 30S	CDT 40S										
Kg	28	32	42	46	34	45										
4	Der Entfeuchter auf die Supports ④/⑤ stellen. Danach mit dem vorderen ① und hinteren Fixierstück ② befestigen. Die Fixierstücke können so angebracht werden, dass die Ausblasseite entweder rechts oder links ist. Auf der Illustration ist sie links.															

**FR** Equerres pour fixation murale, CDT

**Description de la fonction** Une équerre permet de fixer le déshumidificateur sur le mur. Ainsi on aura plus d'espace libre du plancher. Evacuer l'eau condensée en pente vers un égout ou la relever par une pompe de relevage à condensats (option).

**Composants** L'ensemble comprend les composants suivants :

1 support pour la poignée de levage ①	1 longeron, côté droit ④
1 support pour le pied ②	1 longeron, côté gauche ⑤
2 fixations de mur ③	10 vis à tôle

**Outil** Le montage des équerres ne demande aucun outil spécial.

**Attention** Utiliser des vis et des chevilles convenables à la nature de la maçonnerie. (Ces vis ne sont pas compris). Les distances minimums côté aspiration et côté sortie d'air doivent être observées. Ces distances minimums sont indiquées dans le manuel d'instructions du déshumidificateur. Le déshumidificateur doit être mis totalement hors tension avant de le placer sur les équerres.

**Procédure** Veuillez suivre les étapes suivantes pour monter les équerres et placer le déshumidificateur là-dessus:

Étape	Action														
1	Assembler les fixations de mur ③ et les longerons ④/⑤ à l'aide des vis à tôle, utiliser éventuellement le croquis ci-dessous (étapes 2/3)														
2	<p>Monter les équerres sur les mur – marquer d'abord, où percer les trous – selon les indications ci-après:</p> <table border="1"> <tr> <td></td> <td><b>CDT 20/30/30S</b></td> <td><b>CDT 40/40S/60</b></td> </tr> <tr> <td>A</td> <td>335 mm</td> <td>360 mm</td> </tr> <tr> <td>B</td> <td>175 mm</td> <td>175 mm</td> </tr> </table>		<b>CDT 20/30/30S</b>	<b>CDT 40/40S/60</b>	A	335 mm	360 mm	B	175 mm	175 mm					
	<b>CDT 20/30/30S</b>	<b>CDT 40/40S/60</b>													
A	335 mm	360 mm													
B	175 mm	175 mm													
3	<p>Fixer les équerres sur le mur à l'aide des vis convenables pour le matériau du mur (non compris)</p> <table border="1"> <tr> <td></td> <td><b>CDT 20</b></td> <td><b>30</b></td> <td><b>40</b></td> <td><b>60</b></td> <td><b>30S</b></td> <td><b>40S</b></td> </tr> <tr> <td>Kg</td> <td>28</td> <td>32</td> <td>42</td> <td>46</td> <td>34</td> <td>45</td> </tr> </table>		<b>CDT 20</b>	<b>30</b>	<b>40</b>	<b>60</b>	<b>30S</b>	<b>40S</b>	Kg	28	32	42	46	34	45
	<b>CDT 20</b>	<b>30</b>	<b>40</b>	<b>60</b>	<b>30S</b>	<b>40S</b>									
Kg	28	32	42	46	34	45									
4	Placer le déshumidificateur sur les longerons ④/⑤, et le fixer à l'aide du support pour la poignée de levage ① et le support pour le pied ②. Les support ①/② peuvent être placés de sorte que la sortie d'air soit orientée vers la droite ou vers la gauche. Sur le croquis ci-dessus la sortie d'air est orientée vers la gauche.														

**RU** Кронштейн для настенного монтажа, CDT

**Описание** Кронштейн для настенного монтажа позволяет сэкономить пространство на полу. Конденсат следует отводить по линии с уклоном вниз, либо откачивать его при помощи насоса (приобретается отдельно).

**Комплектация** В комплект поставки кронштейна входит:

- 1 фиксатор для транспортировочной ручки ①
- 1 задний фиксатор ②
- 2 настенных планки ③
- 1 правая консоль ④
- 1 левая консоль ⑤
- 10 винтов-саморезов по металлу

**Инструменты** Кронштейн монтируется без использования специального инструмента.

**Внимание** Необходимо использовать дюбели и крепежные винты надлежащего типоразмера (не входит в комплект поставки), которые рекомендуются для данной стены. Обеспечьте минимальный рекомендуемый зазор на заборе и раздаче воздуха. Перед монтажом на стену отключите осушитель от электропитания.

**Монтаж** Для монтажа осушителя на кронштейн выполните следующие действия:

Шаг	Действие														
1	Соедините планки ③ с консолями ④/⑤ с помощью винтов-саморезов (см. рис.)														
2	Просверлите в стене необходимые для монтажа отверстия на расстоянии, указанном в таблице: <table border="1" style="margin: 10px auto;"> <thead> <tr> <th></th> <th>CDT 20/30/30S</th> <th>CDT 40/40S/60</th> </tr> </thead> <tbody> <tr> <td>A</td> <td>335 мм</td> <td>360 мм</td> </tr> <tr> <td>B</td> <td>175 мм</td> <td>175 мм</td> </tr> </tbody> </table>		CDT 20/30/30S	CDT 40/40S/60	A	335 мм	360 мм	B	175 мм	175 мм					
	CDT 20/30/30S	CDT 40/40S/60													
A	335 мм	360 мм													
B	175 мм	175 мм													
3	Закрепите кронштейн на стене с помощью винтов (не входят в комплект поставки), которые рекомендуются для данной стены <table border="1" style="margin: 10px auto;"> <thead> <tr> <th></th> <th>CDT 20</th> <th>30</th> <th>40</th> <th>60</th> <th>30S</th> <th>40S</th> </tr> </thead> <tbody> <tr> <td>Kg</td> <td>28</td> <td>32</td> <td>42</td> <td>46</td> <td>34</td> <td>45</td> </tr> </tbody> </table>		CDT 20	30	40	60	30S	40S	Kg	28	32	42	46	34	45
	CDT 20	30	40	60	30S	40S									
Kg	28	32	42	46	34	45									
4	Установите осушитель на консоли ④/⑤ и закрепите его с помощью фиксаторов ① и ②. Фиксаторы ①/② позволяют установить осушитель в одном из 2 положений: с раздачей сухого воздуха вправо или влево. На рисунке показана схема для раздачи сухого воздуха влево														

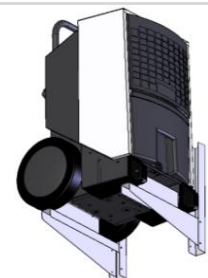
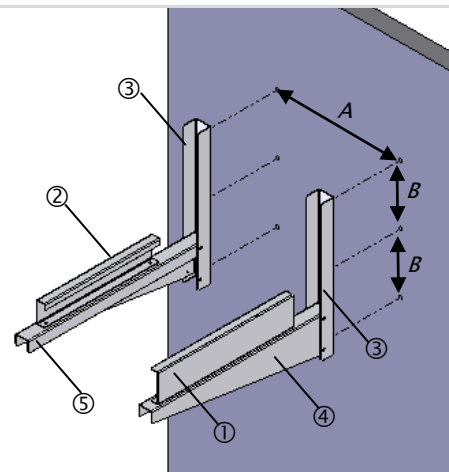



SK

## Nástenná konzola, CDT

### Funkcia

Pomocou nástenných konzol, je možné umiestniť jednotku na stenu a zabezpečiť tak úsporu miesta na podlahe. Odvod kondenzátu samospádom alebo pomocou čerpadla kondenzátu (voliteľné).

### Časti

Sada obsahuje:

- 1 ks predná lišta ①
- 1 ks zadná lišta ②
- 2 ks U-konzoly ③
- 1 ks pravá podpera ④
- 1 ks ľavá podpera ⑤
- 10 ks skrutiek

### Náradie

Na montáž nie je vyžadované žiadne špeciálne náradie.

### Upozornenie

Použite vhodné upevňovacie skrutky a kotvenia (nie sú súčasťou dodávky), pre ukotvenie konzol na stenu

Dodržte minimálny vyžadovaný priestor pre nasávanie a výfuk z jednotky, ktorý je popísaný v návode. Pri montáži musí byť zariadenie vypnuté.

### Montáž

Postupujte podľa nasledovných krokov:

Krok	Popis																
1	Zmontujte U-konzoly ③ a podpery ④/⑤ pomocou skrutiek																
2	Do steny vyvrtajte otvory podľa nasledovnej tabuľky:																
	<table border="1"> <thead> <tr> <th></th> <th>CDT 20/30/30S</th> <th>CDT 40/40S/60</th> </tr> </thead> <tbody> <tr> <td>A</td> <td>335 mm</td> <td>360 mm</td> </tr> <tr> <td>B</td> <td>175 mm</td> <td>175 mm</td> </tr> </tbody> </table>		CDT 20/30/30S	CDT 40/40S/60	A	335 mm	360 mm	B	175 mm	175 mm							
	CDT 20/30/30S	CDT 40/40S/60															
A	335 mm	360 mm															
B	175 mm	175 mm															
3	Konzoly upevnite na stenu pomocou vhodných skrutiek. (nie sú súčasťou dodávky)																
	<table border="1"> <thead> <tr> <th></th> <th>CDT</th> <th>20</th> <th>30</th> <th>40</th> <th>60</th> <th>30S</th> <th>40S</th> </tr> </thead> <tbody> <tr> <td>Kg</td> <td></td> <td>28</td> <td>32</td> <td>42</td> <td>46</td> <td>34</td> <td>45</td> </tr> </tbody> </table>		CDT	20	30	40	60	30S	40S	Kg		28	32	42	46	34	45
	CDT	20	30	40	60	30S	40S										
Kg		28	32	42	46	34	45										
4	Odvlhčovač umiestnite na podpery ④/⑤ a zafixujte ho lištami ① a ②. Lišty ①/② môžu byť umiestnené dvoma spôsobmi: pre výfuk vzduchu vpravo alebo výfuk vzduchu vľavo. Na obrázku je znázornený výfuk vzduchu vľavo.																

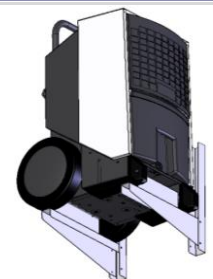
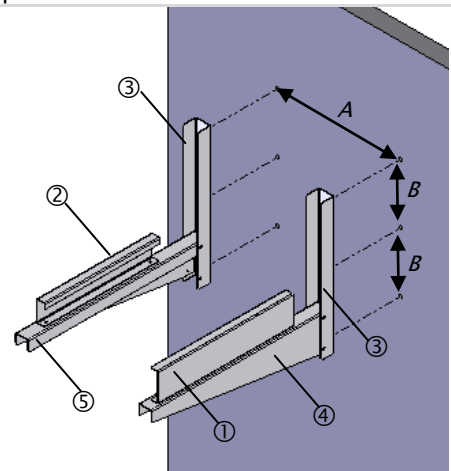

**PT** Suportes de montagem na parede, CDT

**Descrição do funcionamento**

Usando o suporte de montagem de parede terá mais espaço livre no chão. Saída de condensados usando dreno com queda ou bomba de condensados (opção).

**Elementos**

O suporte de montagem inclui os seguintes elementos:

- 1 suporte para pega ①
- 1 suporte traseiro para os pés ②
- 2 suportes de parede ③
- 1 barra, lado direito ④
- 1 barra, lado esquerdo ⑤
- 10 parafusos metálicos

**Ferramentas**

Não são necessárias ferramentas especiais para a montagem do suporte na parede.

**Aviso**

Use parafusos e buchas de montagem apropriadas (não fornecidos) ao tipo de material da parede, para montar o suporte .  
Por favor respeite os espaços de entrada e de saída de ar mencionadas no manual de funcionamento. Desligue o desumidificador antes de proceder à sua montagem no suporte de parede.

**Montagem**

Siga os seguintes passos para realizar a montagem do suporte de parede e para colocar o desumidificador no suporte:

Passo	Acção														
1	Fixe as barras ④/⑤ no suporte de montagem ① usando parafusos de metal, deve usar o esquema com os passos mencionado em 2/3														
2	Monte o suporte na parede, depois de realizados os furos de acordo com a tabela abaixo: <table border="1" style="margin: 10px auto;"> <thead> <tr> <th></th> <th>CDT 20/30/30S</th> <th>CDT 40/40S/60</th> </tr> </thead> <tbody> <tr> <td>A</td> <td>335 mm</td> <td>360 mm</td> </tr> <tr> <td>B</td> <td>175 mm</td> <td>175 mm</td> </tr> </tbody> </table>		CDT 20/30/30S	CDT 40/40S/60	A	335 mm	360 mm	B	175 mm	175 mm					
	CDT 20/30/30S	CDT 40/40S/60													
A	335 mm	360 mm													
B	175 mm	175 mm													
3	Fixe o suporte de parede usando parafusos apropriados (não incluídos) <table border="1" style="margin: 10px auto;"> <thead> <tr> <th></th> <th>CDT 20</th> <th>30</th> <th>40</th> <th>60</th> <th>30S</th> <th>40S</th> </tr> </thead> <tbody> <tr> <td>Kg</td> <td>28</td> <td>32</td> <td>42</td> <td>46</td> <td>34</td> <td>45</td> </tr> </tbody> </table>		CDT 20	30	40	60	30S	40S	Kg	28	32	42	46	34	45
	CDT 20	30	40	60	30S	40S									
Kg	28	32	42	46	34	45									
4	Coloque o desumidificador nas barras ④/⑤, e fixe-o com os suportes ① e ②. Os suportes ①/② podem ser montados de duas formas diferentes: com a entrada de ar à direita ou à esquerda. No esquema a saída de ar está para a esquerda.														

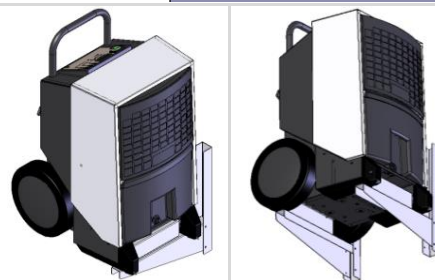
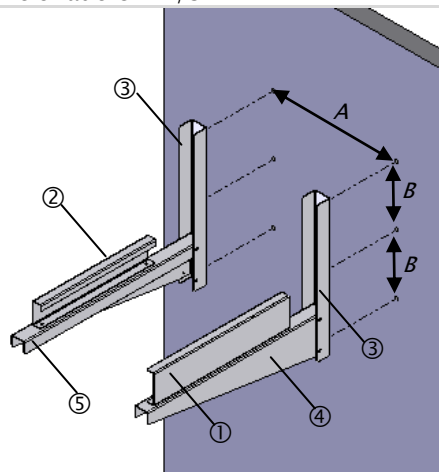

IT **Kit di sospensione a parete, CDT**

**Descrizione funzionale**

L'utilizzo di una staffa da parete consente di incrementare l'area disponibile a pavimento. Scaricare la condensa attraverso uno scarico con pendenza adeguata o utilizzare una pompa per la condensa (opzionale).

**Componenti**

Il kit di sospensione a parete è composto dalle seguenti parti:

- |  |                          |
|--|--------------------------|
| 1 supporto per la maniglia di sollevamento ① | 1 barra, lato destro ④   |
| 1 supporto posteriore per il piede ②         | 1 barra, lato sinistro ⑤ |
| 2 staffe da parete ③                         | 10 viti per lamiera      |

**Utensili**

Non sono necessari utensili speciali per montare il kit di sospensione a parete.

**Attenzione**

Utilizzare viti e spinotti di montaggio adeguati (non fornite) che siano compatibili con lo specifico materiale che costituisce la parete.  
Rispettare gli spazi minimi raccomandati dinanzi alle bocchette di ingresso e uscita dell'aria così come indicati nel manuale di servizio. Spegnere il deumidificatore prima di posizionarlo sulle staffe a parete.

**Montaggio**

Seguire questi passi per montare le staffe di sospensione a parete e appendere il deumidificatore alle staffe:

Punto	Operazione															
1	Assemblare la staffa da parete ③ e le barre ④/⑤ per mezzo delle viti da lamiera; si veda il disegno ai punti 2/3															
2	<p>Applicare le staffe alla parete dopo aver praticato fori in conformità alla seguente tabella:</p> <table border="1"> <thead> <tr> <th></th> <th>CDT 20/30/30S</th> <th>CDT 40/40S/60</th> </tr> </thead> <tbody> <tr> <td>A</td> <td>335 mm</td> <td>360 mm</td> </tr> <tr> <td>B</td> <td>175 mm</td> <td>175 mm</td> </tr> </tbody> </table>		CDT 20/30/30S	CDT 40/40S/60	A	335 mm	360 mm	B	175 mm	175 mm						
	CDT 20/30/30S	CDT 40/40S/60														
A	335 mm	360 mm														
B	175 mm	175 mm														
3	<p>Fissare il kit di sospensione alla parete per mezzo di viti appropriate (non incluse)</p> <table border="1"> <thead> <tr> <th></th> <th>CDT 20</th> <th>30</th> <th>40</th> <th>60</th> <th>30S</th> <th>40S</th> </tr> </thead> <tbody> <tr> <td>Kg</td> <td>28</td> <td>32</td> <td>42</td> <td>46</td> <td>34</td> <td>45</td> </tr> </tbody> </table>		CDT 20	30	40	60	30S	40S	Kg	28	32	42	46	34	45	
	CDT 20	30	40	60	30S	40S										
Kg	28	32	42	46	34	45										
4	<p>Posizionare il deumidificatore sulle barre ④/⑤, e fissarlo tramite i supporti ① e ②. I supporti ①/② possono essere collocati in due modi: sia per l'uscita dell'aria verso destra sia per l'uscita verso sinistra. Nel disegno la bocchetta di uscita dell'aria risulterà orientata verso sinistra</p>															



# Contact Dantherm

Dantherm Air Handling A/S  
Marienlystvej 65  
7800 Skive  
Denmark

Phone +45 96 14 37 00  
Fax +45 96 14 38 00

infodk@dantherm.com  
www.dantherm.com

Dantherm AS  
Postboks 4  
3101 Tønsberg  
Norway  
Besøksadresse: Løkkeåsvn. 26  
3138 Skallestad  
Phone +47 33 35 16 00  
Fax +47 33 38 51 91

dantherm.no@dantherm.com  
www.dantherm.no

Dantherm Air Handling AB  
Virkesgatan 5  
614 31 Söderköping  
Sweden

Phone +(0) 121 130 40  
Fax +(0) 121 133 70

infose@dantherm.com  
www.dantherm.se

---

Dantherm Air Handling (Suzhou) Ltd.  
Bldg#9, No.855 Zhu Jiang Rd.,  
Suzhou New District, Jiangsu  
215219 Suzhou  
China

Phone +86 512 6667 8500  
Fax +86 512 6667 8500

dantherm.cn@dantherm.com  
www.dantherm-air-handling.com.cn

Dantherm Limited  
12 Windmill Business Park  
Windmill Road, Clevedon  
North Somerset, BS21 6SR  
England

Phone +44 (0)1275 87 68 51  
Fax +44 (0)1275 34 30 86

infouk@dantherm.com  
www.dantherm.co.uk

Dantherm Air Handling Inc.  
110 Corporate Drive, Suite K  
Spartanburg, SC 29303  
USA

Phone +1 (864) 595 9800  
Fax +1 (864) 595 9810

infous@dantherm.com  
www.dantherm.com



**Dantherm Air Handling A/S**  
Marienlystvej 65  
7800 Skive  
Denmark  
[www.dantherm.com](http://www.dantherm.com)  
[service@dantherm.com](mailto:service@dantherm.com)

**Dantherm®**  
CONTROL YOUR CLIMATE